

ASSEMBLY AND MAINTENANCE PROCEDURE FOR BONDURA® 6.2

Read the instructions carefully! Bolt Norge AS does not guarantee the product if the assembly and maintenance procedures are not followed. The Bondura bolt is Type Approval Certificated by DNV, and follow the guiding lines by API Specifications 8c, DNV Rules for Lifting Appliances, FEM Rules for Heavy Lifting Appliances, NS 5514 crane standard.

ASSEMBLY PROCEDURE

1. Preparations

- 1.1 Remove any burr. Clean the support.
- 1.2 Align the bolt hole. The middle section must line up with the support on each side. (see Fig. 1). Use a jack or hoist if necessary.

If the bolt is hammered into a hole where the bearing and the support does not line up, the bolt may be damaged.

2. Fitting the bolt

- 2.1 Unscrew the locking plate on the Bondura Bolt and remove the taper sleeve (on the locking side).
- 2.2 Fit the bolt in the joint so that the bolt's tapered end on the locking side is even with the outside of the support (see Fig. 2).

If the bolt is not centre-aligned, the taper sleeve may bottom out in the support before the expansion is completed. The bolt will then be partially loose, and may "cut" the taper screws and lock screws.

Applies to Bondura 6.2 dia 20-65 mm: NOTE! Remember that the locking tab on the bolt must fit into the slot on the locking plate (see Fig. 3a).

3. Fitting taper on locking side

- 3.1 Fit the taper sleeve and fasten the end plate with the plate screws. When tightening the bolt, alternate between the sides to ensure that the bolt does not shift. Tighten to specified torque (see table). Run the equipment for about one hour and retighten to the correct torque. **Retightening after installation is necessary (see "Maintenance").** In Table 1 you will find the required distance "x" from the taper flange to the support before the expansion. It also specifies when the taper sleeve must be replaced with an over-sized taper. In order to prevent moisture from entering from the outside, you may use O-rings or sealing compound on the taper sleeve, between the bolt and support.

4. Locking of Bondura Bolt

The Bondura Bolt does not rotate or slide out because the taper sleeves expand and result in a "wedging force" between the bolt and support.

- 4.1 As an extra precaution, the locking plate must be fastened with a locking screw to the equipment. Use the clamping screw protector to ensure that the locking plate is not bent when tightening the locking screw (see Fig. 3a and 3b).
- 4.2 If requirements from the employer, the screws may be fastened by using a wire through the hole of the screw heads, or using Norlock washers.

Bolt diameter	"X" before expansion	Min. «X». Switch to over-sized taper
20-40	5	1
45-65	8	4
79-95	9	5
100-130	9	5

Bolt diameter	Max. "Y". Switch to over-sized taper	"Y" before expansion
20-40	7	0
45-65	7	0
79-95	7	0
100-130	7	0

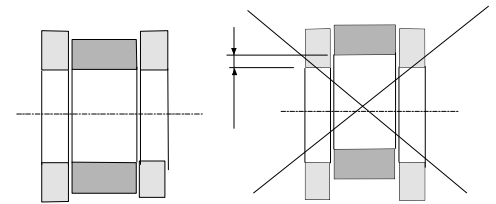

Fig. 1
The support and centre bearing must line up.

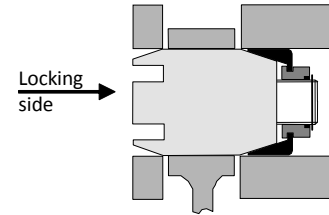

Fig. 2a Correct centring of bolt

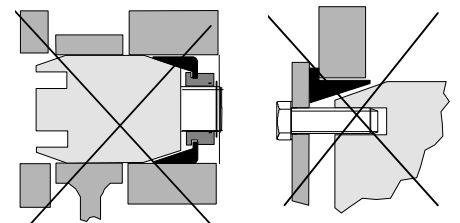

Fig. 2b
Incorrect centring of the bolt results in poor "wedging force"

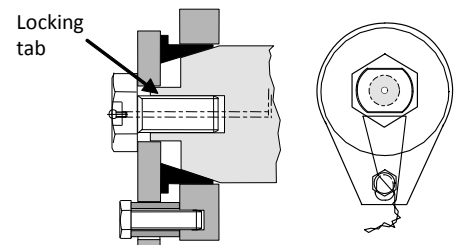

Fig. 3a
Locking of 20-65 mm dia bolt

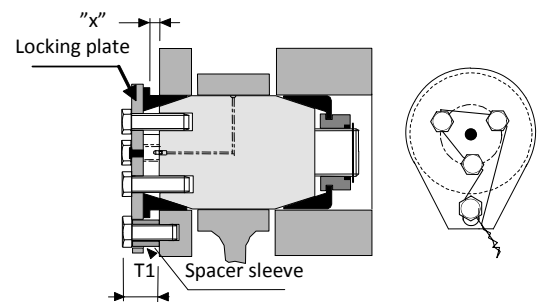

Fig. 3b
Locking of 70-320 mm dia. bolt

Table 1
This shows the acceptable distances "x" and "y" between the taper flange and support

ASSEMBLY AND MAINTENANCE BONDURA® 6.2

MAINTENANCE OF BONDURA® 6.2

Establish procedures for maintenance. This will extend the lifetime of the bolts. Lack of maintenance may result in the bolts coming loose and sliding out of the bolt hole. If this happens, parts of the bolt or equipment may fall down.

5. Bondura Bolt lubrication.

Follow the instructions from the vendors regarding type of grease and frequency. The bolt is lubricated most effectively when it is "unloaded", as the weight of the equipment may prevent lubrication of the bearing surfaces of the bolt.

6. Inspection / retightening

Purpose:

It always takes some time before the bolt and the support is "broken in". The resulting "play" must be absorbed by retightening the screws that holds the taper sleeves in place. When they are retightened, the taper sleeves expand and also absorb wear and ovality in the bolt supports. The taper sleeve may absorb play of up to 2 mm in diameter. If the play is larger, you must use a over-sized taper (see Fig. 4).



Check this box for used equipment. You have to take into consideration the possibility of extra play. Retighten several times during the first 100 hours, before switching to the procedures in Item 6b.

Maintenance of the Bondura Bolt consists of two elements:

a) Inspection

Establish inspection procedures, e.g. every time the bolts are lubricated.

- ❖ That locking plates, taper sleeves and screws are in place.
- ❖ That the bolt cannot rotate (intact anti-rotation lock).
- ❖ That the wire safety is intact.
- ❖ Check that the bolt has not shifted to one side.
- ❖ (if this is the case, see Item 1 under Troubleshooting)

b) Retightening/inspection:

Establish retightening/inspection procedures as specified below.

Equipment**Interval**

Travelling block / clevis	Annually
Bail / top drive link	3 times per year
Other top drive bolts	2 times per year
Dolly	2 times per year
Drill string compensator	Annually
Pipe handling machinery, cranes	Annually
Drawworks	Annually

- ❖ Check that the distance between the taper flange and support is not less than the min distance between the taper flange and support must be the same (within approx. 2 m. Normally the play will be the same in both supports. If you are in doubt as to whether is possible to unscrew the plate and check the bolt. If the distance is less than min. "x"
 - a) the bolt has shifted to one side
 - b) the play in the supports is too great for the taper sleeve (exceeds 2 mm). Switch t
- ❖ Tighten the bolt screws to the specifies torque in order to expand the taper sleeves. F The weight of the equipment may prevent effective tightening (see Fig. 5).

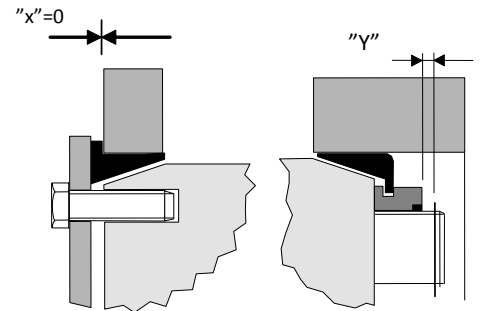

Fig. 4.

Too much play results in no "wedging force". Switch to over-sized taper. "X" is measured between the taper flange and support.

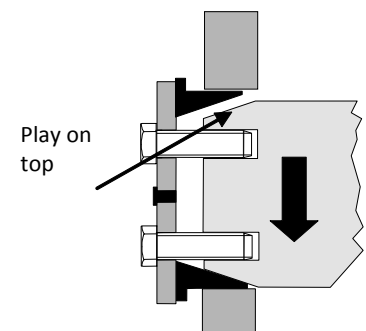

Fig. 5.

A heavy load on the bolt prevents complete tightening. Unload the bolt before tightening.

ASSEMBLY AND MAINTENANCE BONDURA® 6.2

7. Troubleshooting**- If the bolt "rotates" or cuts the lock screws:**

- * Check that the bolt is properly centre-aligned (see Item 2, Fig. 2)
- * Tighten the bolt screws in order to expand the taper sleeves.
- * Check that the distance between the taper flange and support side is not less than the min. "x" stated in Table 1. If this is the case, the play in the support is too great for the taper sleeve (exceeds 2 mm). Switch to over-sized taper.
- * If the bolt still rotates, it may be that the bearing surface on the bolt or bearing liner is "torn" and must be replaced.

- If there is axial movement in the bolt, and it no longer is centre-aligned in the supports:

- * Check that the bolt screws are properly tightened and that the distance "x" between the taper flange and support is not smaller than stated in Table 1. If necessary, switch to over-sized taper.

8. Disassembly of type 6.2 Bondura Bolt

The equipment must always be unloaded before starting the disassembly.

8.1 Unscrew the locking plate.

8.2 In most cases the tapers may be removed by using a pry bar/chisel between the support and the taper flange. We recommend using penetrating oil first. In case of large bolt dimensions or problems, use a "taper puller" to pull off the taper sleeves, see "Pullers».

8.3. In most instances, the bolts will come out easily. Another option is to pull out the bolts by screwing on the locking plate and using a puller / jack on the locking plate. On larger bolt dimensions or in the event of problems, the bolt can be pulled out using a hydraulic jack. "Pullers".

Bondura 6.2 dia 44,4 – 65 mm

Locking screw	1
Bolt	4
Seegering	8
Nipple	10
Taper K1	13
Taper K6	16
M2 Nut	19
Locking plate	20
Bolt screw	25
Wacher	34
Screw protector	37

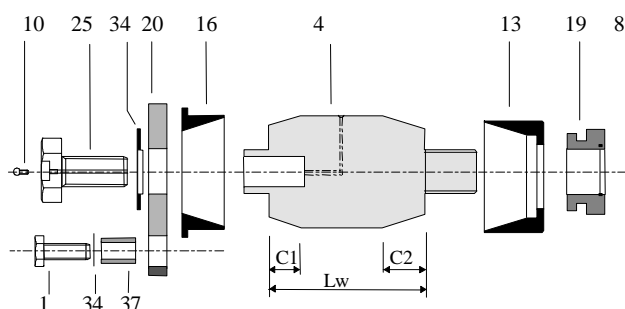
**Bondura 6.2 dia 70 – 130 mm**

Locking screw	1
Bolt	4
Seegering	8
Nipple	10
Taper K1	13
Taper K6	16
M2 Nut	19
Locking plate	20
Bolt screw	26
Washer	34
Screw protector	37

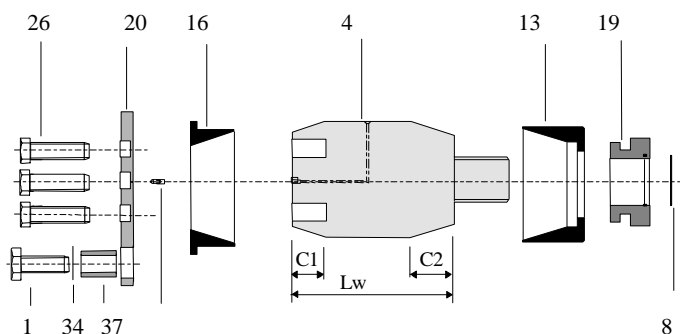

ASSEMBLY AND MAINTENANCE BONDURA® 6.2

Dimensions and data for Bondura type 6.2

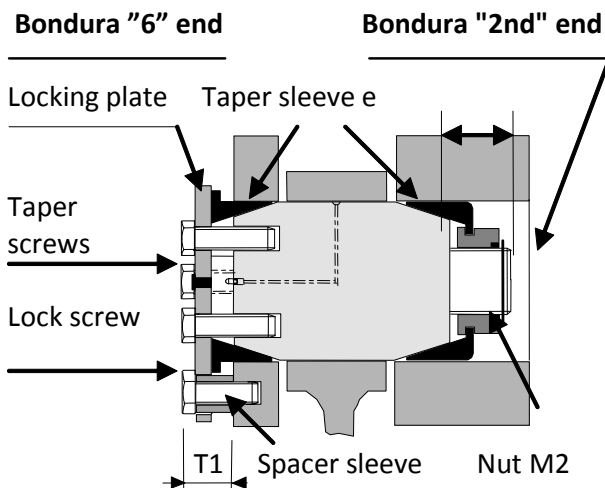
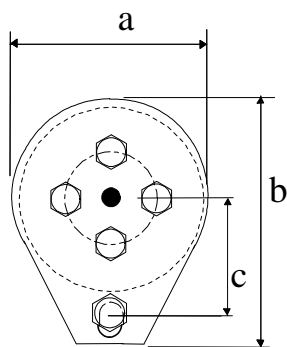

Design 44,4-65 mm dia.

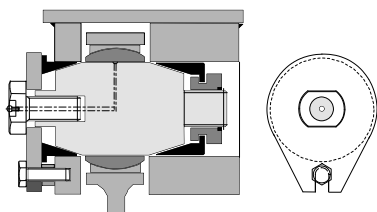

Design 70-130 mm dia.

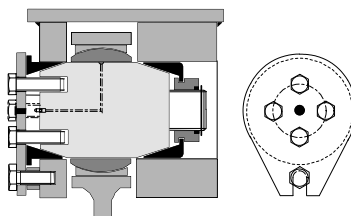

All locking plates has a hole for through sleeve and lock screw. This is to prevent the locking plate falling down if anything should happen to the plate screws.

Bondura "2nd" end	Bolt dim.	Spanner	Torque	"e"
Nut M2 18	44,4- 59 mm	NV 30	200 - 260 Nm	30
Nut M2 24	60 - 74 mm	NV 41	400 – 550 Nm	36
Nut M2 36	60 - 71 mm	NV 50	700 – 900 Nm	40
Nut M2 42	72 - 91 mm	NV 55	1000 - 1500 Nm	40
Nut M2 56	92 - 111 mm	NV 75	1500 - 2000 Nm	43
Nut M2 56	112 - 131 mm	NV 75	1700 - 2200 Nm	43

BOLT DIA	DIMENSION				LOCK SCREW	PLATE SCREWS		
	see dimensioned drawings					M	Torque (Nm) dry	Spanner gap NV(mm)
mm	a	b	c	T1 max	Lock screw dimensions			
20	37	50	23	23	M10 x 30 3/8UNCx1 1/4"	43	17	2 stk.M10
25 - 30	37	50	28	23	M10 x 30 3/8UNCx1 1/4"	73	19	2 stk.M12
31,8-40	46	67	31	23	M10 x 30 3/8UNCx1 1/4"	177	24	2 stk.M16
44,4-65	71	113	55	28	M 12 x 40 7/16UNCx1 1/2"	346	30	2 stk.M20
70- 80	101	141	61	31	M 16 x 40 5/8UNCx1 3/4"	115	22	6 stk.M14
85-95	101	141	66	31	M 16 x 40 5/8UNCx1 3/4"	150	24	6 stk.M16
100-110	133	179	78	40	M 20 x 50 3/4UNCx2"	177	24	8 stk.M16
114-127	133	179	85	43	M 20 x 50 3/4UNCx2"	346	30	6 stk.M20

All torque value in dry condition. For lubricate value- reduce with 10%. 1Nm =0,737 ft*lb

ASSEMBLY AND MAINTENANCE BONDURA® 6.2

STANDARD BONDURA® BOLT PROGRAM

Bondura® 6.1 is used where there is access only from one side, or limited access on one side. The bolt is installed from one side. The inner taper sleeve is tightened via the centre shaft. Both taper sleeves are tightened (serviced) from one side.

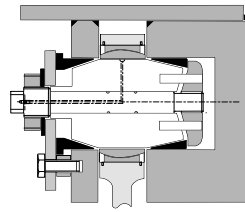
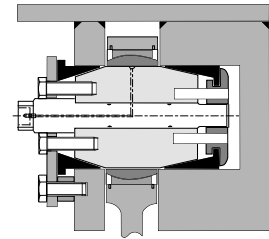
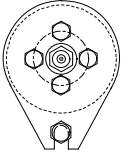
**Bondura® 6.1** dia. 30-57 mm**Bondura® 6.1** dia. 60-180 mm

Bondura® 6.2 is used in non-fixed joints when one or both supports are extra wide. This solution is also used when the bolt cannot protrude past the support on one side, but where there is access to tighten the bolt from both sides.

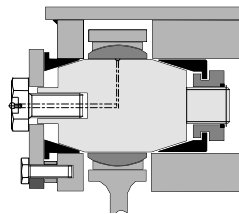
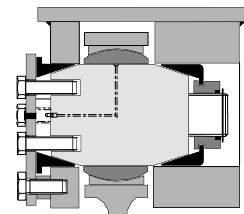
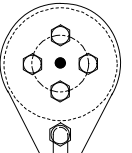
**Bondura® 6.2** dia. 30-65 mm**Bondura® 6.2** dia. 70-120 mm

Bondura® 6.6 fits most bolt locations in non-fixed joints. The bolt requires access from both sides in order to tighten the bolt screws.

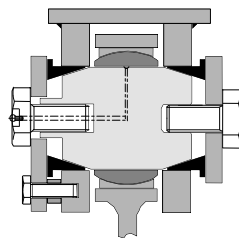
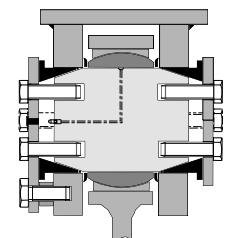
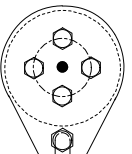
**Bondura® 6.6** dia. 20-65 mm**Bondura® 6.6** dia. 70-320 mm

Bondura® 3.6.3.6 has expanding taper sleeves on both outer and inner support, ensuring a fixed connection also in the middle segment. Examples of applications for this bolt are in fixed structural connections such as framed structures and when joining sections. It is also used in self-aligning plain bearings where the bolt is "locked" to the inner sleeve of the bearing. When the inner taper sleeves expand during installation, this ensures that the bearing does not turn on the bolt surface.

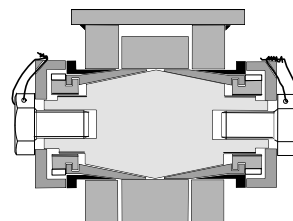
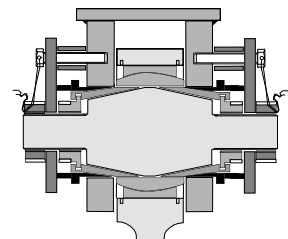
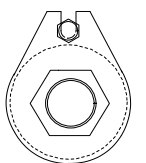
**Bondura® 3.6.3.6** dia. 30-80 mm**Bondura® 3.6.3.6** dia. 90-320 mm

Bondura® 3.1 and 3.3 are first generation expanding bolts. They are now replaced mainly by 6.1 and 6.6 with the exception of special bolt positions

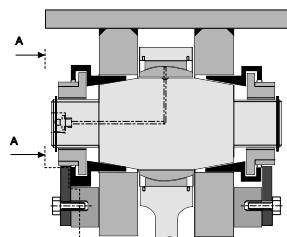
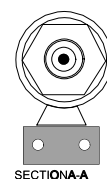
**Bondura® 3.3** dia. 30-200 mm

SECTION A-A

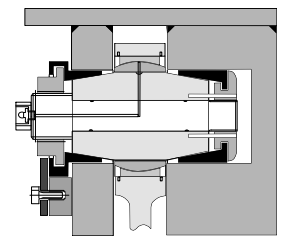
**Bondura® 3.1** dia. 60-140 mm